

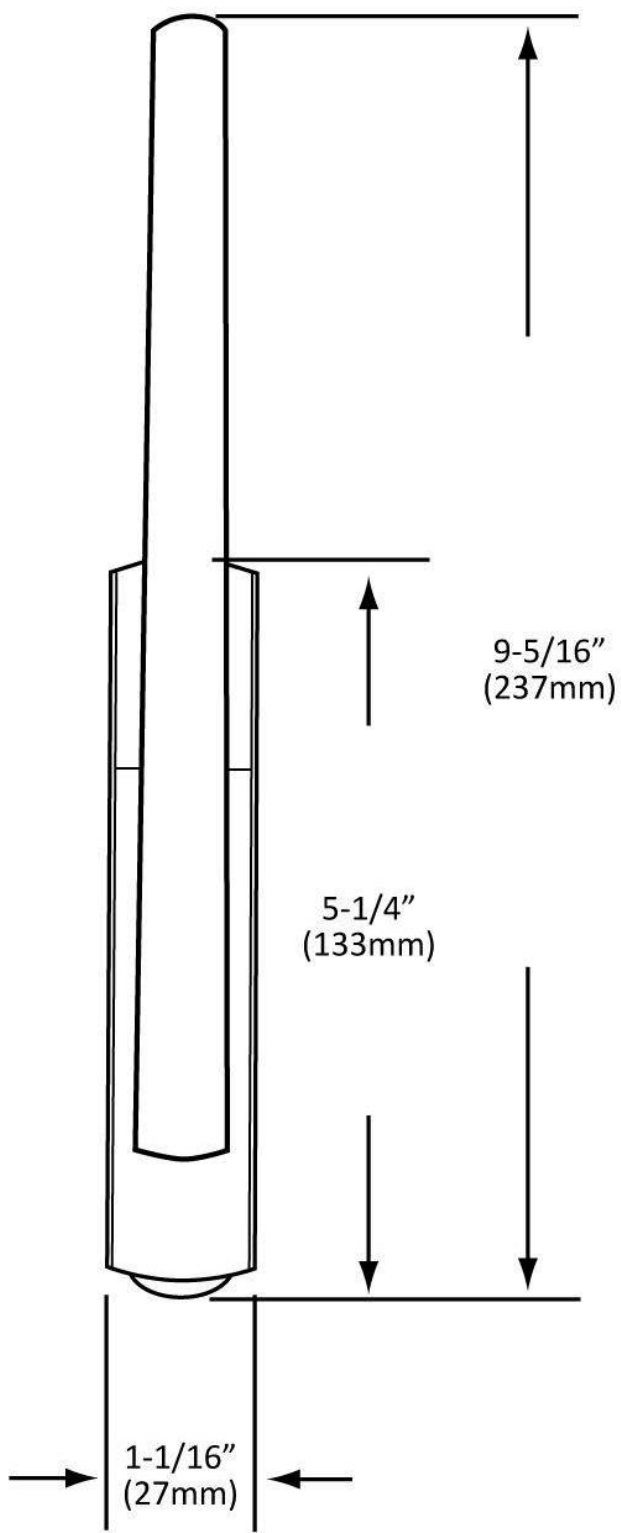

VENTFAB

DRILLED & COUNTERSUNK
TO SUIT #10 SCREWS



R26-1000

