

W60 SERIES LIFT-OFF HINGE WITH CAM RISE ACTION



W60 SERIES HINGE - LONG STRAP POLISHED CHROME FINISH

MODEL NO.	OFFSET
W60-1000	FLUSH
W60-1012	1/8" (3mm)
W60-1025	1/4" (6mm)
W60-1037	3/8" (10mm)
W60-1112	1-1/8" (29mm)
W60-1125	1-1/4" (32mm)
W60-1137	1-3/8" (35mm)
W60-1150	1-1/2" (38mm)
W60-1162	1-5/8" (41mm)
W60-1175	1-3/4" (45mm)
W60-1187	1-7/8" (48mm)
W60-1200	2" (51mm)

W60 SERIES HINGE - SHORT STRAP POLISHED CHROME FINISH

W60-1000-S	FLUSH
W60-1012-S	1/8" (3mm)
W60-1025-S	1/4" (6mm)
W60-1037-S	3/8" (10mm)

COORDINATED STYLING

Design coordinated with clean, unobtrusive lines to aesthetically complement the **W19 AND W38 SERIES EASY ACTION SAFETY LATCH** or other contemporary breaker hardware, latches or pulls.

REVERSIBLE

Can be utilized for any right or left hand door application. Conversion is easily accomplished without tools.

UNIQUE CAM ACTION

Contains self-lubricating nylon and Delrin cam rise components to provide **GLIDE-ACTION** door operation. These components reduce door sweep gasket wear regardless of floor irregularity and provide constant overclose pressure against the door gasket assuring a positive seal. A **HOLD-OPEN** feature is built into the cam allowing the door to remain open at 140°. The door will automatically return to a closed position if opened less than 140°.

LIFT-OFF CAPABILITY

Doors can be removed quickly without tools or hinge disassembly. This allows for knockdown shipment and eliminates costly on-site installation and service time.

DURABLE

Constructed of die-cast Zamak with built-in structural reinforcing ribs for extraordinary strength and years of trouble-free operation.

ALL TYPE CONSTRUCTION

This series is designed to meet the universal requirements of all types of cooler construction especially foam.

UNIVERSAL MOUNTING HOLES

Allows REPLACEMENT* with all competitors models without redrilling or reinforcing.

• W60 SPECIFICATIONS LISTED ON NEXT PAGE

W60 SERIES HINGES

SPECIFICATIONS

- OFFSET:** Flush thru 2" (51mm)
FINISH: Polished Chrome or Satin Chrome Finish
MATERIAL: High pressure die cast Zamak
MOUNTING HOLES: Drilled and countersunk for #14 screws (6mm)

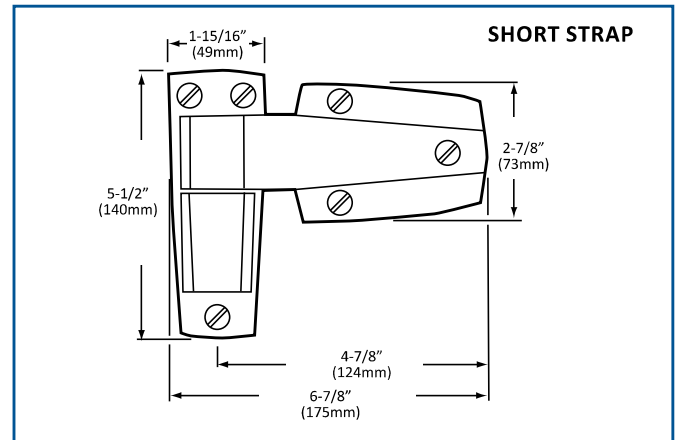
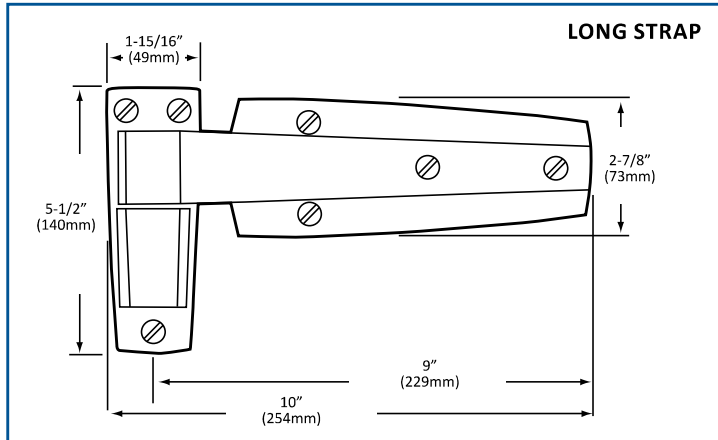

POWER SPRING CONVERSION CARTRIDGE KIT

MODEL NO. W62-0001 Polished Chrome Finish

- ACCELERATES DOOR CLOSING
- INCREASES DOOR PRESSURE
- EASY INSTALLATION
- REDUCED INVENTORY

The energy saving power spring conversion cartridge is designed for easy installation into the W60 Series Lift-off Hinge. It provides increased door speed closure and maintains constant gasket pressure to eliminate refrigerated air loss. Unlike competitor's spring hinges, this optional cartridge kit can be simply added at any time to the W60 Series Lift-off Hinge eliminating costly inventories.

The cartridge kit contains a heavy duty chrome vanadium spring to assure years of trouble-free operation. The assembly may be used for either left or right hand doors, permitting reduced inventory for both hinges and conversion kits. When required, the cartridge may be easily disengaged for door removal.

Note: This conversion cartridge eliminates the lift-off capability of the W60 SERIES LIFT-OFF HINGE.

EASY INSTALLATION

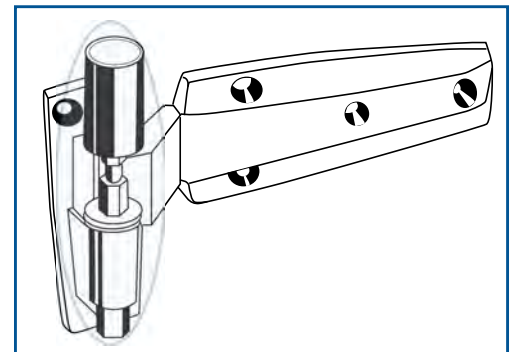
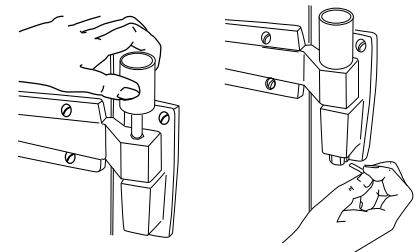

W60 SERIES HOLE PATTERN

